



WELLHEAD  
DISTRIBUTORS  
INTERNATIONAL

*API-6A Wellhead*

## *Compact Tubing Heads*

WDI's Compact Tubing Heads tubing heads are a low cost tubing suspension solution for fracturing or recompletion applications. The head features a versatile straight bore design for single completion capable of supporting up to a 5" hanger. This design allows for full-bore access up to 5-1/2" casing (or smaller). The hanger can be landed through 4" valves, eliminating the need for larger valves and BOPs. WDI's Compact Tubing Heads accept a wide variety of tubing hanger styles including mandrel and wrap-around

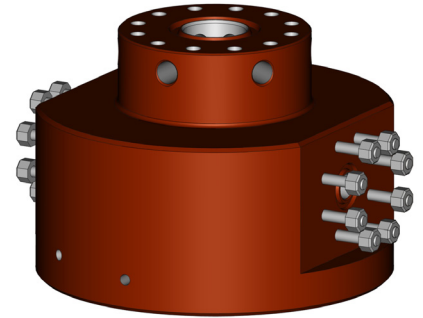

### *Features*

#### **Available Sizes**

- Available up to 5-1/8" 10M configuration.
- Flanged or studded connections, top and bottom, are available

#### **Straight bore design**

- Features a 45° landing shoulder capable of supporting maximum loads

#### **Outlets**

- Studded Side Outlets

#### **Manufacturing Standard (needs to be verified)**

- API-6A, PSL-1, DD, L-U, PR-1 (3M & 5M)
- API-6A, PSL-2, DD, L-U, PR-1 (10M)

#### **Bottom Preparations**

- PE/BG bottom for use with PE secondary seal
- Double P seal
- Double O-ring
- Additional variations available upon request

#### **Availability**

- Additional sizes available upon request
- Available with ET (integral) style lockscrews



## Compact Tubing Heads

### Specifications

Bottom Flange Size	Working Pressure	Top Flange Size	Working Pressure	Outlet	BTM Prep	BTM Prep	BTM Prep
7-1/16"	5M	4-1/16"	10M	1-13/16" 10M	Double P	Double O-ring	Single P and Single O-ring
7-1/16"	5M	4-1/16"	10M	1-13/16" 10M	Double P	Double O-ring	Single P and Single O-ring
11"	5M	5-1/8"	10M	1-13/16" 10M	Double P	Double O-ring	Single P and Single O-ring
11"	5M	5-1/8"	10M	2-1/16" 10M	Double P	Double O-ring	Single P and Single O-ring

**Wellhead Distributors International**

4606 FM 1960 W, Suite 560  
Houston, Texas 77069 USA  
Tel: (281) 448-1000  
Fax: (281) 448-1001  
[www.wellheadistributors.com](http://www.wellheadistributors.com)